

8

Treatment and disposal technologies for health-care waste

Incineration used to be the method of choice for most hazardous health-care wastes and is still widely used. However, recently developed alternative treatment methods are becoming increasingly popular. The final choice of treatment system should be made carefully, on the basis of various factors, many of which depend on local conditions:

- disinfection efficiency;
- health and environmental considerations;
- volume and mass reduction;
- occupational health and safety considerations;
- quantity of wastes for treatment and disposal/capacity of the system;
- types of waste for treatment and disposal;
- infrastructure requirements;
- locally available treatment options and technologies;
- options available for final disposal;
- training requirements for operation of the method;
- operation and maintenance considerations;
- available space;
- location and surroundings of the treatment site and disposal facility;
- investment and operating costs;
- public acceptability;
- regulatory requirements.

Certain treatment options presented in this chapter may effectively reduce the infectious hazards of health-care waste and prevent scavenging but, at the same time, give rise to other health and environmental hazards. For example, incineration of certain types of health-care waste, particularly those containing chlorine or heavy metals, may under certain conditions (such as insufficiently high incineration temperatures, inadequate control of emissions) release toxic material into the atmosphere. Land disposal may result in groundwater pollution if the landfill site is inadequately designed and/or operated. In choosing a treatment or disposal method for health-care waste, particularly if there is a risk of toxic emissions or other hazardous consequences, the relative risks, as well as the integration into the overall framework of comprehensive waste strategy, should therefore be carefully evaluated in the light of local circumstances.

Advantages and drawbacks of the various treatment and disposal technologies discussed in this chapter are summarized in Table 8.4 (page 110).

8.1 Incineration

8.1.1 *Principles of incineration*

Incineration is a high-temperature dry oxidation process that reduces organic and combustible waste to inorganic, incombustible matter and

results in a very significant reduction of waste volume and weight. This process is usually selected to treat wastes that cannot be recycled, reused, or disposed of in a landfill site. The process flow is illustrated schematically in Fig. 8.1.

The combustion of organic compounds produces mainly gaseous emissions, including steam, carbon dioxide, nitrogen oxides, and certain toxic substances (e.g. metals, halogenic acids), and particulate matter, plus solid residues in the form of ashes. If the conditions of combustion are not properly controlled, toxic carbon monoxide will also be produced. The ash and wastewater produced by the process also contain toxic compounds, which have to be treated to avoid adverse effects on health and the environment.

Most large, modern incinerators include energy-recovery facilities. In cold climates, steam and/or hot water from incinerators can be used to feed urban district-heating systems, and in warmer climates the steam from incinerators is used to generate electricity. The heat recovered from small hospital incinerators is used for preheating of waste to be burnt.

Required waste characteristics

Incineration of waste is affordable and feasible only if the “heating value” of the waste reaches at least 2000kcal/kg (8370kJ/kg). The value for infectious waste, for instance, exceeds 4000kcal/kg. The characteristics that make waste suitable for incineration are listed in Box 8.1.

Fig. 8.1 Simplified flow scheme of incinerator

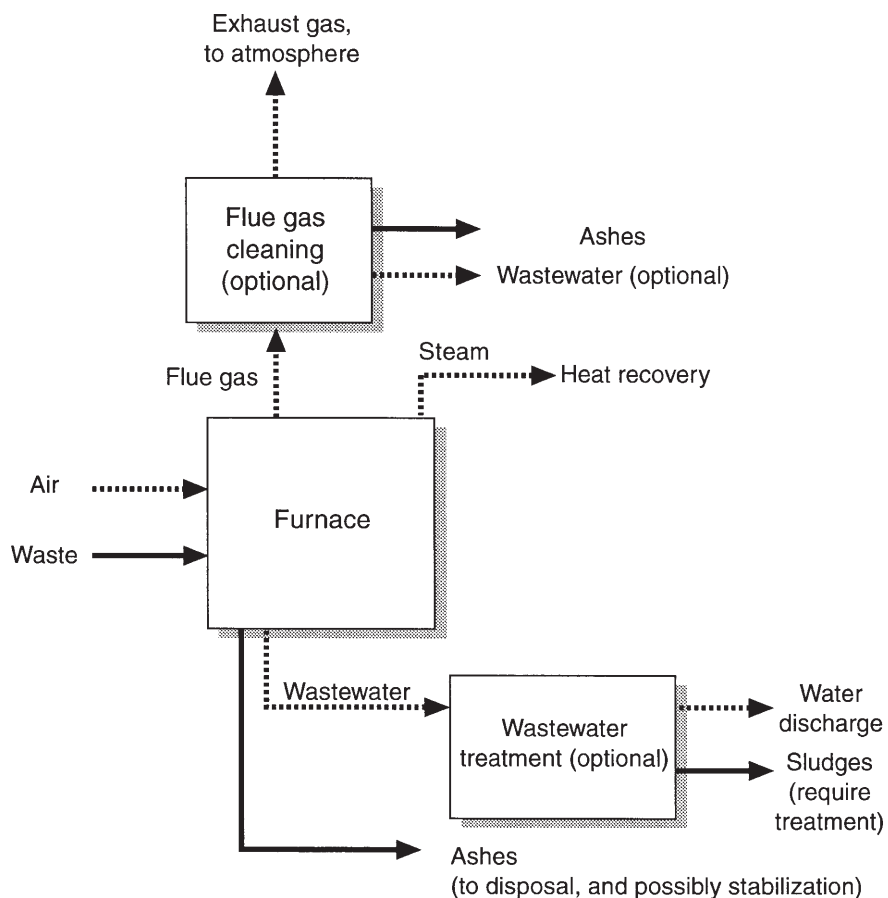

WHO 86529

An input of appropriate fuel may overcome a slightly deficient heating value or a slightly excessive moisture content.

Incineration requires no pretreatment, provided that certain waste types are not included in the matter to be incinerated. Wastes that should not be incinerated are listed in Box 8.2.

Types of incinerator

Incinerators can range from extremely sophisticated, high-temperature operating plants to very basic combustion units that operate at much lower temperatures. All types of incinerator, if operated properly, eliminate pathogens from waste and reduce the waste to ashes. However, certain types of health-care wastes, e.g. pharmaceutical or chemical wastes, require higher temperatures for complete destruction. Higher operating temperatures and cleaning of exhaust gases limit the atmospheric pollution and odours produced by the incineration process.

Incineration equipment should be carefully chosen on the basis of the available resources and the local situation, and of risk–benefit considerations—balancing the public health benefits of pathogen elimination

Box 8.1 Characteristics of waste suitable for incineration

- Low heating value: above 2000 kcal/kg (8370 kJ/kg) for single-chamber incinerators, and above 3500 kcal/kg (14640 kJ/kg) for pyrolytic double-chamber incinerators.
- Content of combustible matter above 60%.
- Content of non-combustible solids below 5%.
- Content of non-combustible fines below 20%.
- Moisture content below 30%.

Box 8.2 Waste types not to be incinerated

- Pressurized gas containers.
- Large amounts of reactive chemical waste.
- Silver salts and photographic or radiographic wastes.
- Halogenated plastics such as polyvinyl chloride (PVC).
- Waste with high mercury or cadmium content, such as broken thermometers, used batteries, and lead-lined wooden panels.
- Sealed ampoules or ampoules containing heavy metals.

before waste disposal against the potential risks of air or groundwater pollution caused by inadequate destruction of certain wastes.

Three basic kinds of incineration technology are of interest for treating health-care waste:

- double-chamber pyrolytic incinerators, which may be especially designed to burn infectious health-care waste;
- single-chamber furnaces with static grate, which should be used only if pyrolytic incinerators are not affordable;
- rotary kilns operating at high temperature, capable of causing decomposition of genotoxic substances and heat-resistant chemicals.

Incinerators designed especially for treatment of health-care waste should operate at temperatures between 900 and 1200°C. Low-cost, high-temperature incinerators of simple design are currently being developed, and a system designed specifically for health-care and pharmaceutical waste in low-income countries is currently under test in England, at De Montfort University.

Mobile incinerators for health-care waste have been tested in Brazil. These units permit on-site treatment in hospitals and clinics, thus avoiding the need to transport infectious waste through city streets. Test results for units with a capacity of 30 kg/hour were satisfactory in terms of function, performance, and air pollution (Bartone, 1998).

High-temperature incineration of chemical and pharmaceutical waste in industrial cement or steel kilns is practised in many countries and is a valuable option; no additional investments are required and industry benefits from a supply of free combustible matter.

Assessment of waste parameters

Specific waste parameters should be assessed at the planning stage to determine the most suitable type and size of incinerator:

- current extent of waste production and types of health-care waste;
- estimated future waste production;
- production of incinerable waste per day (and per bed per day);
- all the physical parameters that determine the suitability of waste for incineration, such as low heating value and moisture content (see Box 8.1).

8.1.2 Pyrolytic incinerators

Technology

The most reliable and commonly used treatment process for health-care waste is pyrolytic incineration, also called controlled air incineration or double-chamber incineration. The main characteristics of pyrolytic incinerators, which may be especially designed for hospitals, are summarized in Box 8.3.

The pyrolytic incinerator comprises a pyrolytic chamber and a post-combustion chamber and functions as follows:

- In the pyrolytic chamber, the waste is thermally decomposed through an oxygen-deficient, medium-temperature combustion process (800–900°C), producing solid ashes and gases. The pyrolytic chamber

Box 8.3 Characteristics of pyrolytic incinerators

Adequate for the following waste categories:

- *Infectious waste (including sharps) and pathological waste*
— efficient treatment; elimination of all pathogens.
- *Pharmaceutical and chemical residues*
— causes disintegration of most residues; however, only small amounts (e.g. 5% of total waste load) of these wastes should be incinerated in this process.

The low heating value of the wastes should exceed 3500kcal/kg (14650kJ/kg).

Inadequate for the following wastes:

- *Non-risk health-care waste similar to urban waste*
— pyrolytic incineration would waste resources.
- *Genotoxic waste*
— treatment probably not efficient.
- *Radioactive waste*
— treatment does not affect radioactive properties and may disperse radiation.

Wastes that should not be incinerated:

- *Pressurized containers*
— may explode during incineration and cause damage to the equipment.
- *Halogenated plastics such as PVC*
— exhaust gases may contain hydrochloric acids and dioxins.
- *Wastes with high heavy-metal content*
— incineration will cause emission of toxic metals (e.g. lead, cadmium, mercury) into the atmosphere.

Incineration temperature: 800–900°C.

Incinerator capacity: Available capacities range from 200kg/day to 10 tonnes/day. Hospitals are usually equipped with incinerators with a capacity of less than 1 tonne/day.

Exhaust-gas cleaning equipment: Needed for larger facilities.

Additional remarks: The equipment is relatively expensive to purchase, and expensive to operate and maintain. Well trained personnel are required.

includes a fuel burner, used to start the process. The waste is loaded in suitable waste bags or containers.

- The gases produced in this way are burned at high temperature (900–1200°C) by a fuel burner in the post-combustion chamber, using an excess of air to minimize smoke and odours.

Larger pyrolytic incinerators (capacity 1–8 tonnes/day) are usually designed to function on a continuous basis. They may also be capable of fully automatic operation, including loading of waste, removal of ashes, and internal movement of burning waste.

Adequately maintained and operated pyrolytic incinerators of limited size, as commonly used in hospitals, do not require exhaust-gas cleaning equipment. Their ashes will contain less than 1% unburnt material,

which can be disposed of in landfills. However, to avoid dioxin production, no chlorinated plastic bags (and preferably no other chlorinated compounds) should be introduced into the incinerator, and should therefore not be used for packaging waste before its incineration.

Design and size of a pyrolytic incinerator

Optimal combustion conditions are essential if there is to be almost complete destruction of wastes without the generation of significant amounts of harmful solid, liquid, or gaseous outputs (e.g. dioxins, furans). The burning temperature, waste residence time inside the furnace, gas turbulence, and size of airflow inputs are therefore critical, and the incinerator should fulfil the following criteria:

- The temperature in the post-combustion chamber should reach at least 900°C, and gas residence time should be at least 2 seconds; air inflow with 100% excess oxygen and high turbulence should be ensured.
- The pyrolytic chamber should be of sufficient size to allow a residence time for the waste of 1 hour. It should contain baffles or dampers to increase the mixing of waste with the air inflow.
- The pyrolytic and post-combustion chambers should be of steel with an internal lining of refractory bricks, resistant to corrosive waste or gas and to thermal shock.
- The feed opening should be large enough to allow the loading of packed waste. The size of the ash removal opening should be appropriate for the expected percentage of incombustibles in the waste. There should be provision for accumulated ashes to cool down before disposal.
- The incinerator should be operated, monitored, and regulated from a central console, which should include a continuous display of operating parameters and conditions (temperature, airflow, fuel flow, etc.).

A computerized facility for programming automatic operation is very useful—but not essential—for maintaining good operating conditions, in particular when the heating value varies widely as may be the case for health-care waste.

Operation and maintenance of pyrolytic incinerators

The pyrolytic incinerator should be operated and monitored by a well trained technician who can maintain the required conditions, controlling the system manually if necessary. Correct operation is essential, not only to maximize treatment efficiency and minimize the environmental impact of emissions, but also to reduce maintenance costs and extend the life expectancy of the equipment. A careful operational balance needs to be maintained between the two combustion chambers. If this is not done, the following are the likely consequences:

- Too rapid combustion of waste will increase the flow of gas and decrease its residence time to below the minimum desired period of 2 seconds. This may result in partial, rather than complete, combustion of the gases and an increase in the soot and slag produced, which may clog the system and lead to major maintenance problems.
- If the pyrolytic combustion of waste is too slow, the flow speed of gases in the post-combustion chamber will be reduced. This may reduce air pollution, but will result in lower incinerating capacity and higher fuel consumption.

Fuel consumption of pyrolytic incinerators is between 0.03 and 0.08 kg of fuel-oil per kg of waste, or between 0.04 and 0.1 m³ of gas fuel per kg of waste.

Periodic maintenance includes cleaning of the combustion chambers and declogging of air inflows and fuel burners, when necessary. Operators in charge of loading waste and removing ashes should wear protective equipment—masks, gloves, safety glasses, overalls, and safety shoes.

On-site and off-site facilities

The choice of on-site (i.e. at the hospital) or off-site (at a central location) incineration facilities should be in line with the national planning policies discussed in section 5.3. Only technical parameters are described here.

Small-scale incinerators used in hospitals, of capacity 200–1000 kg/day, are operated on demand. They are manually loaded and de-ashed daily or every 2–3 days; a shovel or a vacuum cleaner should be used to remove the ashes. The combustion process is under automatic control and the services of an operator are therefore required for only part of a working day (e.g. 2 hours). The various activities involved in operating this type of incineration unit are summarized in Box 8.4.

Off-site regional facilities will have large-scale incinerators of capacity 1–8 tonnes/day, operating continuously and equipped with automatic loading and de-ashing devices. Incinerators of this size would benefit from energy-recovery systems—at least for preheating of the waste to be incinerated—and exhaust-gas cleaning facilities. It may be possible to use the steam produced to generate electricity. Facilities should also be available for the treatment and final disposal of incineration by-products. Operation and maintenance of a large, centralized, pyrolytic incinerator of capacity 4–8 tonnes/day will require the full-time services of a waste disposal engineer.

Box 8.4 Activities involved in operation of a pyrolytic hospital incinerator

- Removal of ashes left inside the pyrolytic chamber (after cooling down).
- Loading of waste packages to be incinerated.
- Ignition of fuel burner in post-combustion chamber.
- Ignition of the pyrolytic fuel burner to start waste burning in the pyrolytic chamber.
- Pyrolysis of waste and monitoring of gas production.
- Monitoring high-temperature burning of gas inside post-combustion chamber.
- Stopping the fuel burners after completion of waste and gas burning, and letting the incinerator cool down.

Table 8.1 *Approximate costs of pyrolytic incinerators (Europe, 1996)*

Incinerator equipment	Investment costs (in 1000 US\$) for capacities (tonnes/day) of				
	0.4	1	2	4	8
Without energy recovery or gas cleaning	50	100	120	150	230
With energy recovery but without gas cleaning	100	180	230	340	570
With energy recovery and gas cleaning	300	400	480	600	780

Ideally, large-scale incinerators should be located in industrial areas specially designated for hazardous plants. Such areas have good road access and power and water supplies, and are usually remote from housing. In any case, incinerators must be located at a minimum distance of 500 metres from any human settlement.

Investment and operating costs

Capital costs for pyrolytic incinerators suitable for treating health-care waste vary widely. For illustrative purposes only, approximate costs of equipment available on the European market in 1996 are given in Table 8.1.

In Europe, operating and maintenance costs for a small-scale hospital pyrolytic incinerator may reach about US\$ 380 per tonne of waste incinerated.

8.1.3 Rotary kilns

A rotary kiln, which comprises a rotating oven and a post-combustion chamber, may be specifically used to burn chemical wastes, and is also suited for use as a regional health-care waste incinerator. The main characteristics of rotary kilns are summarized in Box 8.5.

The axis of a rotary kiln is inclined at a slight angle to the vertical (3–5% slope). The kiln rotates 2 to 5 times per minute and is charged with waste at the top. Ashes are evacuated at the bottom end of the kiln. The gases produced in the kiln are heated to high temperatures to burn off gaseous organic compounds in the post-combustion chamber and typically have a residence time of 2 seconds.

Rotary kilns may operate continuously and are adaptable to a wide range of loading devices. Those designed to treat toxic wastes should preferably be operated by specialist waste disposal agencies and should be located in industrial areas or “parks”.

8.1.4 Incineration in municipal incinerators

It is economically attractive to dispose of infectious health-care waste in municipal incinerators if these are located reasonably close to hospitals. As the heating value of health-care waste is significantly higher than that of domestic refuse, the introduction of relatively small quantities of health-care waste will not affect the operation of a municipal incinerator. Municipal incinerators are usually of a double-chamber design, with an operating temperature of 800°C in the first combustion chamber and gas combustion in the second chamber at temperatures of, typically, 1000–1200°C.

Box 8.5 Characteristics of rotary kilns

Adequate for the following waste categories:

- *Infectious waste (including sharps) and pathological waste.*
- *All chemical and pharmaceutical wastes, including cytotoxic waste.*

Inadequate for the following wastes:

- *Non-risk health-care waste*
 - incineration in rotary kilns would represent a waste of resources.
- *Radioactive waste*
 - treatment does not affect radioactive properties and may disperse radiation.

Wastes that should not be incinerated:

- *Pressurized containers*
 - may explode during incineration and cause damage to the equipment.
- *Wastes with high heavy-metal content*
 - incineration will cause emission of toxic metals (e.g. lead, cadmium, mercury) into the atmosphere.

Incineration temperature: 1200–1600 °C, which allows decomposition of very persistent chemicals such as PCBs (polychlorobiphenyls).

Incinerator capacity: Available capacities range from 0.5 to 3 tonnes/hour.

Exhaust-gas cleaning and ash treatment equipment: Likely to be needed, as the incineration of chemical waste produces exhaust gases and ashes that may be loaded with toxic chemicals.

Additional remarks: Equipment and operation costs are high, as is energy consumption. Wastes and incineration by-products are highly corrosive, and the refractory lining of the kiln often has to be repaired or replaced. Well trained personnel are required.

A number of rules and recommendations apply to the disposal of health-care wastes in municipal facilities:

- When health-care waste is delivered to the incineration plant, the packaging should be checked to ensure that it is undamaged.
- Health-care waste should not be packed in cylindrical containers, because these could roll on the grids where they are placed for combustion.
- Facilities should be available at the incineration site for the cleaning and disinfection of transportation equipment, including vehicles.
- Deposit of health-care waste in the normal reception bunker is not recommended: there is a risk of waste bags being damaged during transfer to the furnace by the overhead crane. Health-care waste should therefore be loaded directly into the furnace.
- Use of an automatic loading device for bags and containers of health-care waste, rather than manual loading, would protect the safety of workers.
- Health-care waste should not be stored for more than 24 hours at an incineration plant; longer storage would require cooling facilities

to prevent the growth of certain pathogens and the development of odours.

- The combustion efficiency should be checked. It should be at least 97% during incineration of health-care waste.
- Health-care waste should be introduced into the furnace only when the normal conditions of combustion have been established—never during start-up or shutdown of the combustion process.
- The process should be designed to prevent contamination of ashes or wastewater by the health-care waste.

Wastes that should *not* be incinerated are the same as those listed for pyrolytic incinerators (section 8.1.2).

8.1.5 Incineration options that meet minimum requirements

Single-chamber incinerator

If a pyrolytic incinerator cannot be afforded, health-care waste may be incinerated in a static-grate, single-chamber incinerator with the characteristics summarized in Box 8.6. This type of incinerator treats waste in batches; loading and de-ashing operations are performed manually. The combustion is initiated by addition of fuel and should then continue unaided. Air inflow is usually based on natural ventilation from the oven mouth to the chimney; if this is inadequate, however, it may be assisted by mechanical ventilation. Regular removal of soot and slags is essential.

Atmospheric emissions will usually include acid gases such as sulfur dioxide, hydrogen chloride, and hydrogen fluoride, black smoke, fly ash (particulates), carbon monoxide, nitrogen oxide, heavy metals, and volatile organic chemicals. To limit these emissions, the incinerator should be properly operated and carefully maintained, and sources of pollution should be excluded from the waste to be incinerated whenever possible.

The different types of single-chamber incinerators range from the simple to the sophisticated. Different types of simple design are illustrated in Figs 8.2 and 8.3; the Bailleul single-chamber incinerator shown in Fig. 8.4 can be used as a guideline for design.

Drum incinerator and brick incinerator

A “drum” or “field” incinerator is the simplest form of single-chamber incinerator. It should be used only as a last resort as it is difficult to burn the waste completely without generating potentially harmful smoke. The option is appropriate only in emergency situations during acute outbreaks of communicable diseases and should be used only for infectious waste.

The drum incinerator should be designed to allow the intake of sufficient air and the addition of adequate quantities of fuel—essential to keep the temperature as high as possible. A 210-litre (55 US gallon) steel drum should be used, with both ends removed; this will allow the burning of one bag of waste at a time (see Fig. 8.5). A fine screen placed on the top of the drum will prevent some of the ash or light material from blowing out. Another screen or fine grate should be placed under the drum, and a chimney may also be fitted (Fig. 8.6). This type of incinerator can also be fabricated from sheet metal or clay.

To operate the drum incinerator, a good fire should first be established on the ground underneath it. One bag of waste should then be lowered into

Box 8.6 Characteristics of single-chamber incinerators

Adequate for the following waste categories:

- Infectious waste (including sharps) and pathological waste. Pathogens are eliminated if the incinerator is correctly operated. Ashes should contain <3% unburnt matter.
- General health-care waste (similar to domestic refuse). This type of waste may be incinerated, particularly if the low heating value exceeds 4000kcal/kg (16740kJ/kg).

Inadequate for the following wastes:

- Pharmaceutical and chemical residues. The process is of limited suitability for these wastes and is not generally recommended; exhaust gases may contain toxic substances, such as dioxins. For safety reasons, therefore, large quantities of these wastes should not be introduced into this type of incinerator.
- Genotoxic waste. Treatment by this means is not efficient.
- Radioactive waste. This type of treatment has no effect on radioactive properties and may actually cause dispersal of radioactivity.
- Inorganic compounds and thermally resistant waste.

Waste that should not be incinerated:

- Pressurized containers. Explosion may occur and cause damage to the equipment.
- Halogenated plastics (e.g. PVC). Exhaust gases contain hydrogen chloride and may contain dioxins.
- Wastes with high content of heavy metals (e.g. thermometers, batteries). Incineration will cause emission of toxic metals (e.g. lead, cadmium, mercury) into the atmosphere.

Incineration temperature: 300–400 °C.

Incinerator capacity: 100–200 kg/day.

Exhaust gas cleaning: Not usually practicable; this type of incinerator should therefore not be installed where air pollution is already a problem.

the drum. Tying the bag to a stick with string will help to avoid burns. Wood should be added to the fire until the waste is completely burned. After burning is complete, the ashes from both the fire and the waste itself should be collected and buried safely inside the premises of health-care facilities (see section 8.5.3).

A “brick incinerator”, for use in similar circumstances, may be built by constructing a closed area with brick or concrete walls.

The efficiency of this type of incinerator may reach 80–90% and result in destruction of 99% of microorganisms and a dramatic reduction in the volume and weight of waste. However, many chemical and pharmaceutical residues will persist if temperatures do not exceed 200 °C. In addition, the process will cause massive emission of black smoke, fly ash, and potentially toxic gases.

Fig. 8.2 Apparatus for controlled burning



Fig. 8.3 Single-chamber incinerator



8.1.6 Environmental control technology for incinerators

General principles

Incinerator emissions should comply with the national standards. If the relevant authorities have not established such standards, they may refer to standards in force in Europe or the USA for instance (see Tables 8.2 and 8.3).

Fig. 8.4 Bailleul single-chamber incinerator^a

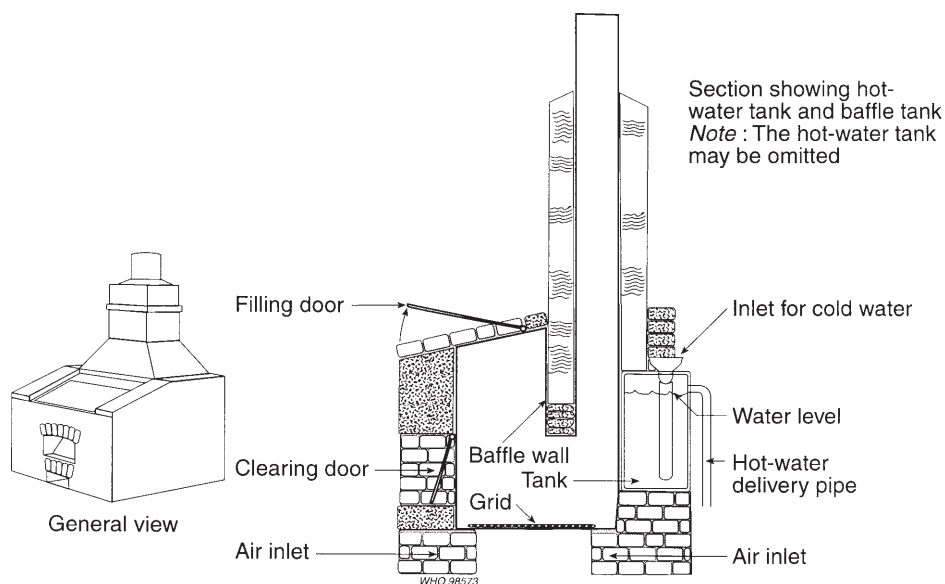

^a Source: Christen (1996), used with permission.

Fig. 8.5 Drum incinerator^a

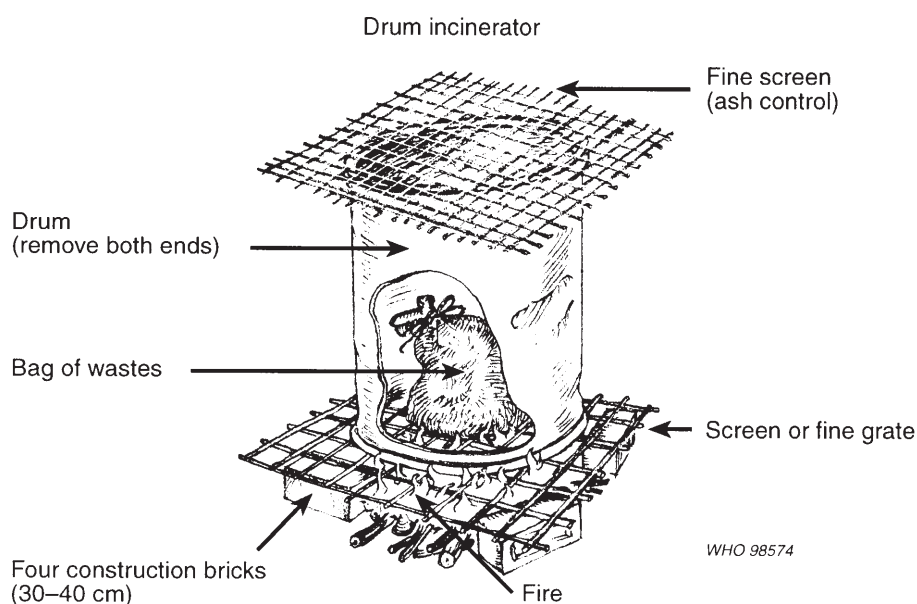

^a Source: Dunsmore (1986).

Flue (exhaust) gases from incinerators contain fly ash (particulates), composed of heavy metals, dioxins, furans, thermally resistant organic compounds, etc., and gases such as oxides of nitrogen, sulfur, and carbon, and hydrogen halides. If flue gases are to be treated, this must be done in at least two different stages—“de-dusting”, to remove most of the fly ash, followed by washing with alkaline substances to remove hydrogen

Fig. 8.6 Drum incinerator with chimney



halides and sulfur oxides. These treatments are briefly described below. Catalytic oxidation of carbon monoxide and reduction of nitrogen oxides are not common procedures; optimal adjustment of the combustion conditions is the best means of keeping production of these gases to a minimum.

Wastewater from gas washing and quenching of ashes should undergo a chemical neutralization treatment before being discharged into a sewer; the treatment includes neutralization of acids and flocculation and precipitation of insoluble salts. Sludges from wastewater treatment and from cooling of fly ash should be considered as hazardous waste. They may either be evacuated to a waste disposal facility for hazardous chemicals, or be treated on-site by drying followed by encapsulation in drums which are then filled up with cement mortar and may be disposed of in a landfill. The encapsulation process prevents the rapid leakage of chemicals.

The solid ashes in the incineration residue are far less hazardous than fly ash, and in the past have been reused in civil engineering works. Recently, however, growing concern about potential leakage of toxic substances from these ashes and subsequent pollution of groundwaters has led a number of countries to insist that the ashes are disposed of in landfills designed specifically for potentially hazardous substances.

Table 8.2 *Emission guidelines for “hospital/medical/infectious waste” incinerators^a*

Note: These standards and guidelines also establish requirements for operator training/qualification, waste management plans, and testing/monitoring of pollutants and operating parameters. The standards for new incinerators also include siting requirements.

Pollutant	Small incinerator (≤91 kg/hour)	Medium incinerator (>91–227 kg/hour)	Large incinerator (>227 kg/hour)
<i>A. Emission limits for new incinerators (construction after June 1996)</i>			
Particulate matter	115 mg/m ³	69 mg/m ³	
Carbon monoxide (CO)	40 ppmv	40 ppmv	
Dioxins/furans	125 ng/m ³ total CCD/CDF or 2.3 ng/m ³ TEQ	125 ng/m ³ total CCD/CDF or 2.3 ng/m ³ TEQ	125 ng/m ³ total CCD/CDF or 2.3 ng/m ³ TEQ
Hydrogen chloride (HCl)	100 ppmv or 93% reduction	100 ppmv or 93% reduction	100 ppmv or 93% reduction
Sulfur dioxide (SO ₂)	55 ppmv	55 ppmv	55 ppmv
Nitrogen oxides	250 ppmv	250 ppmv	250 ppmv
Lead	1.2 mg/m ³ or 70% reduction	1.2 mg/m ³ or 70% reduction	1.2 mg/m ³ or 70% reduction
Cadmium	0.16 mg/m ³ or 65% reduction	0.16 mg/m ³ or 65% reduction	0.16 mg/m ³ or 65% reduction
Mercury	0.55 mg/m ³ or 85% reduction	0.55 mg/m ³ or 85% reduction	0.55 mg/m ³ or 85% reduction
<i>B. Emission limits for existing incinerators (construction started before June 1996)</i>			
Particulate matter	115 mg/m ³	69 mg/m ³	34 mg/m ³
Carbon monoxide (CO)	40 ppmv	40 ppmv	40 ppmv
Dioxins/furans	125 ng/m ³ total CCD/CDF or 2.3 ng/m ³ TEQ	125 ng/m ³ total CCD/CDF or 2.3 ng/m ³ TEQ	125 ng/m ³ total CCD/CDF or 2.3 ng/m ³ TEQ
Hydrogen chloride (HCl)	100 ppmv or 93% reduction	100 ppmv or 93% reduction	100 ppmv or 93% reduction
Sulfur dioxide (SO ₂)	55 ppmv	55 ppmv	55 ppmv
Nitrogen oxides	250 ppmv	250 ppmv	250 ppmv
Lead	1.2 mg/m ³ or 70% reduction	1.2 mg/m ³ or 70% reduction	1.2 mg/m ³ or 70% reduction
Cadmium	0.16 mg/m ³ or 65% reduction	0.16 mg/m ³ or 65% reduction	0.16 mg/m ³ or 65% reduction
Mercury	0.55 mg/m ³ or 85% reduction	0.55 mg/m ³ or 85% reduction	0.55 mg/m ³ or 85% reduction
<i>C. Emission limits for existing incinerators that meet rural criteria, i.e. at a certain distance from metropolitan areas and incinerating less than 908 kg/week (construction started before June 1996)</i>			
Particulate matter		197 mg/m ³	
Carbon monoxide (CO)		40 ppmv	
Dioxins/furans		800 ng/m ³ total CDD/CDF or 15 ng/m ³ TEQ	
Hydrogen chloride (HCl)		3100 ppmv	
Sulfur dioxide (SO ₂)		55 ppmv	
Nitrogen oxides		250 ppmv	
Lead		10 mg/m ³	
Cadmium		4 mg/m ³	
Mercury		7.5 mg/m ³	

^aAdapted from: Environmental Protection Agency (1997). Standards of performance for new stationary sources and emission guidelines for existing sources: hospital/medical/infectious waste incinerators; final rule. *Federal register*, 62(178).

ppmv = parts per million in volume.

CDD = polychlorinated dibenzo-*p*-dioxins.

CDF = polychlorinated dibenzofurans.

TEQ = 2,3,7,8-tetrachlorinated dibenzo-*p*-dioxin toxic equivalent based on the 1989 international toxic equivalency factors.

Table 8.3 *Standards for incinerator emissions in the European Union*

Emission	Daily average (mg/m ³) ^a	Hourly average (mg/m ³) ^a	4-hour average (mg/m ³) ^a
Total dust	5	10	—
Total organic carbon	5	10	—
Chlorine compounds	5	10	—
Fluorine compounds	1	2	—
Sulfur oxides as SO ₂	25	50	—
Nitrogen oxides as NO ₂	100	200	—
Carbon monoxide	50	100	—
Mercury	—	—	0.05
Cadmium and thallium	—	—	0.05
Lead, chromium, copper, and manganese	—	—	0.5
Nickel and arsenic	—	—	0.5
Antimony, cobalt, vanadium, and tin	—	—	0.5
Dioxins and furans	—	—	0.1
Oxygen content	at least 6% at any moment		

^aMeasurements made at standard temperature and pressure.

After de-dusting and acid neutralization, flue gases are emitted through the incinerator stack, the design of which should comply with national regulations. In France, for example, regulations require that the stack design ensures a minimum gas exit speed of 12 m/s.

Dust removal

The design of flue-gas cleaning facilities assumes normal operation of the incinerator, especially as regards temperature and air inputs. The facilities are not designed to cope with the consequences of poor operation, such as massive production of soot and/or slag.

Flue gas emerges from the post-combustion chamber at about 800 °C and must be cooled to 300 °C before entering the dust-removal equipment. This is usually achieved in cooling towers, called quenching towers or baths, where the gas is cooled by water circulating in a closed system. (The water may subsequently be used for preheating of waste or for other purposes.) Cooling of the flue gas may also be effected by the introduction of fresh air, although this method is less efficient.

Incineration produces between 25 and 30 kg of dust per tonne of waste; an incinerator of x tonnes/day capacity should therefore be equipped with dust-removal equipment that can deal with $30x$ kg/day of dust.

The most common types of dust-removal equipment used in incinerator plants are briefly described in the following paragraphs.

Cyclonic scrubbers are static devices in which gases circulate in spiral movements, and centrifugal forces separate the particulate matter. Efficiency in removing very small particulate matter (diameter <15 μm) is low, and cyclonic scrubbers therefore provide only a preliminary dust removal; treatment by electrofilter (see below) usually follows. Some improvement in the efficiency of cyclonic scrubbers may be effected by water injection along the axis of the cylinder.

Fabric dust removers, also called *baghouse filters*, are widely used. They are highly efficient, but investment and operating costs are relatively high, and the life of the equipment is limited at high temperatures. The filters are made of jute or synthetic textiles that are relatively resistant to chemical aggression. Flue gas is blown through the filter fabric, which retains the particulate matter. The particulate matter is automatically removed from the bags at intervals, by reverse airflow or by mechanical means.

Electrofilters, also called *electrostatic precipitators*, are highly efficient (efficiency 99% or better) and are extensively used in large municipal incinerators of capacity in excess of 5 tonnes/hour. Operating costs are moderate but initial investment costs high. The flue gas is brought into contact with a series of electrodes at a potential of 1000–6000 volts. Particulate matter becomes electrically charged and is deposited on the electrodes, from which it is removed mechanically.

Removal of acids or alkalis

Three processes—known as wet, semi-wet, and dry—are available for the removal of acids such as hydrofluoric acid (HF), hydrochloric acid (HCl), and sulfuric acid (H₂SO₄). In the *wet process*, gases are washed in a spraying tower with soda or lime solution, which also contributes to gas cooling and to the removal of very small particulates. The alkaline solution is continuously recycled, with occasional replacement of some of the solution. (Acidic spray may be used if flue-gas alkalinity is a problem.) Wastewater generated by the process requires treatment by chemical neutralization, flocculation, and settling of sludges before it is discharged into a sewer. In the *semi-wet process*, a lime suspension is injected into the gas column. Salts generated by the neutralization process have to be removed. In the *dry process*, lime powder is injected into the gas column; again, salts produced during the neutralization have to be removed.

The wet process is the most efficient of these three options, but requires complex treatment of the resultant wastewater.

8.2 Chemical disinfection

8.2.1 Simple chemical disinfection processes

Chemical disinfection, used routinely in health care to kill microorganisms on medical equipment and on floors and walls, is now being extended to the treatment of health-care waste. Chemicals are added to waste to kill or inactivate the pathogens it contains; this treatment usually results in disinfection rather than sterilization. Chemical disinfection is most suitable for treating liquid waste such as blood, urine, stools, or hospital sewage. However, solid—and even highly hazardous—health-care wastes, including microbiological cultures, sharps, etc., may also be disinfected chemically, with the following limitations:

- Shredding and/or milling of waste is usually necessary before disinfection; the shredder is often the weak point in the treatment chain, being subject to frequent mechanical failure or breakdown.
- Powerful disinfectants are required, which are themselves also hazardous and should be used only by well trained and adequately protected personnel.
- Disinfection efficiency depends on operational conditions.
- Only the surface of intact solid waste will be disinfected.

Human body parts and animal carcasses should not normally be disinfected chemically. If alternative facilities for disposal are not readily available, however, they may be shredded and then subjected to chemical disinfection. In planning the use of chemical disinfection, requirements for the eventual disposal of the residues should be carefully considered; improper disposal could give rise to serious environmental problems.

Microbial resistance to disinfectants has been investigated and it is possible to list the major groups of microorganisms from most to least resistant as follows: bacterial spores—mycobacteria—hydrophilic viruses—lipophilic viruses—vegetative fungi and fungal spores—vegetative bacteria. A disinfectant known to be effective against a particular group of microorganisms will also be effective against all the groups that are less resistant. Most parasites, such as *Giardia* and *Cryptosporidium* spp., are significantly resistant to disinfection and are usually rated between the mycobacteria and the viruses.

The effectiveness of disinfection is estimated from the survival rates of indicator organisms in standard microbiological tests.

At present, chemical disinfection of health-care waste is limited in industrialized countries. However, it is an attractive option for developing countries, particularly for treating highly infectious physiological fluids, such as patients' stools in case of cholera outbreaks.

Chemical disinfection is usually carried out on hospital premises. Recently, however, commercial, self-contained, and fully automatic systems have been developed for health-care waste treatment and are being operated in industrial zones. The disinfected waste may be disposed of as non-risk health-care waste, but the chemical disinfectants may create serious environmental problems in case of leakage or after disposal.

Chemical disinfection of hospital sewage requires less powerful—and less hazardous—chemicals, and is discussed further in Chapter 10.

Operational considerations

The speed and efficiency of chemical disinfection will depend on operational conditions, including the following:

- the kind of chemical used;
- the amount of chemical used;
- the contact time between disinfectant and waste;
- the extent of contact between disinfectant and waste;
- the organic load of the waste;
- operating temperature, humidity, pH, etc.

Shredding of waste before disinfection

Shredding of solid health-care waste before disinfection is essential for the following reasons:

- to increase the extent of contact between waste and disinfectant by increasing the surface area and eliminating any enclosed spaces;
- to render any body parts unrecognizable to avoid any adverse visual impact on disposal;
- to reduce the volume of waste.

Water is usually added during shredding; it prevents excessive warming and facilitates subsequent contact with the disinfectant. Excess water may have to be treated, e.g. by chemical disinfection.

Rotating-blade shredders are used most commonly, and consist of blades attached to two wheels that rotate in opposite directions. The presence of an excessive proportion of sharps in waste may cause deterioration of the shredder.

Shredding of waste before disinfection plus subsequent compacting can reduce the original waste volume by 60–90%.

Types of chemical disinfectants

The aim of disinfection is to eliminate microorganisms or at least reduce their numbers to a “satisfactory” level. Some disinfectants are effective in killing or inactivating specific types of microorganisms and others are effective against all types. It is therefore essential to know the identity of the target microorganisms to be destroyed. However, selection of disinfectants depends not only on their effectiveness, but also on their corrosiveness and other hazards related to their handling. More comprehensive information on disinfectants is provided in Chapter 14 (section 14.3.5).

The types of chemicals used for disinfection of health-care waste are mostly aldehydes, chlorine compounds, ammonium salts, and phenolic compounds; the characteristics of those most commonly used for waste applications are outlined in Boxes 8.7 to 8.11. The use of ethylene oxide is no longer recommended for waste treatment because of the significant hazards related to its handling. However, it has been used in the past and may still be in use in some places, and its characteristics are therefore outlined in Box 8.8 for the sake of completeness.

The use of ozone (O₃) for disinfection of waste is currently being investigated. This disinfectant is strong and relatively safe. The process would be similar to the wet thermal process, described in section 8.3.

Most of the disinfectants described here are stable for at least 5 years and—with the exception of sodium hypochlorite—remain effective for 6–12 months after opening of the container.

Powerful disinfectants are often hazardous and toxic; many are harmful to skin and mucous membranes. Users should therefore wear protective clothes, including gloves and protective eye glasses or goggles. Disinfectants are also aggressive to certain building materials and should be handled and stored accordingly.

Small amounts of disinfectants can be discharged into sewers without pretreatment, provided that there is an adequate sewage-treatment process; large amounts of disinfectants should never be discharged into sewers. No disinfectants should be discharged into natural water bodies.

Chemical disinfection costs and equipment

For the disinfection of waste, capital investment costs are in the range US\$ 50 000–100 000; operating costs, which are generally in the range US\$ 100–120 per tonne, are heavily dependent on the price of chemical disinfectants, which may vary from country to country. Where relatively cheap chemical disinfectants are easily available on the local market,

Box 8.7 Characteristics of formaldehyde (HCHO) as a chemical disinfectant

Application

Inactivating effect against all microorganisms, including bacteria, viruses, and bacterial spores; may be applied to dry, solid waste, in combination with steam at 80°C. Contact time: 45 minutes.

Physical and chemical properties

Gas at ambient temperature; flammable and explosive in mixtures with air at concentrations of 7–73%; reactive at ambient temperature; polymerizes at temperatures below 80°C. Formalin is a 37% solution of formaldehyde. Formaldehyde odour threshold: 0.1–1 ppm.

Health hazards

WHO guideline value for the general public: 0.1 ppm. WHO guideline value for occupational exposure: 1 ppm for 5 minutes, with no more than 8 peaks in one working period (of up to 8 hours). Irritant effects may be experienced at concentrations of 1–3 ppm upwards; exposure to concentrations above 10 ppm may result in severe irritation of eyes or respiratory tract. Occupational safety limit: 1 ppm in the USA. Formaldehyde has been classified as a probable human carcinogen by the International Agency for Research on Cancer; all precautions should therefore be taken to avoid inhalation of this compound during handling. NIOSH IDLH: 20 ppm.¹

Protective measures

Gloves and protective eye glasses should be worn during handling of formaldehyde to protect skin and eyes; in case of skin contact, the affected area should be rinsed abundantly with water.

Corrosiveness

Formalin is slightly corrosive to most metals except stainless steel and aluminium; it should be stored in stainless steel, aluminium, or polyethylene containers, in well ventilated, leakage-proof rooms.

Fire

Firefighters should wear breathing masks when tackling fires involving formaldehyde.

Comments

Formaldehyde is suitable for use as a chemical disinfectant only in situations in which a high level of chemical safety can be maintained.

¹National Institute for Occupational Safety and Health/Immediately Dangerous to Life or Health (concentration).

chemical disinfection is an economically attractive treatment option. However, the process is not very popular in developing countries at present, and the choice of equipment is therefore limited. It seems that the best available reacting tanks are of the “Virhoplan” type, incorporating a shredder and designed to operate with ethylene oxide gas.

Box 8.8 Characteristics of ethylene oxide (CH₂OCH₂) as a chemical disinfectant

Application

Inactivating effect against all microorganisms, including bacteria, viruses, and bacterial spores; disinfection of solid waste at temperatures of 37–55 °C, at 60–80% humidity, for 4–12 hours.

Physical and chemical properties

Gas at temperatures above 10 °C; flammable and explosive in mixtures with air at concentrations of 3% and above; very reactive at ambient temperature; soluble in water and most organic solvents. Odour threshold: 320–700 ppm.

Health hazards

Liquid ethylene oxide and aqueous solutions are extremely irritant to skin and eyes; occupational safety limit: 1–5 ppm (depending on the country). Ethylene oxide has been classified as a human carcinogen by the International Agency for Research on Cancer; all precautions should therefore be taken to avoid inhalation of this compound during handling. NIOSH IDLH: 800 ppm.

Protective measures

Gloves and protective eye glasses should be worn during handling of ethylene oxide to protect skin and eyes; in case of skin contact, the affected area should be rinsed abundantly with water; in case of eye contact, the eyes should be rinsed abundantly with water for at least 15 minutes, followed by medical examination; immediate hospital attention is needed in case of inhalation or ingestion; continuous monitoring of ethylene oxide should be performed.

Corrosiveness

Ethylene oxide is corrosive to rubber and plastics but not to metal; it is usually stored in pressurized metal containers, in liquid form, under high-pressure nitrogen gas.

Fire

Ethylene oxide fires are very difficult to stop; in case of fire, gas inflow should be stopped; CO₂ or powder extinguishers should be used; firefighters should wear protective masks.

Comments

The use of ethylene oxide is not recommended because of significant related health hazards.

8.2.2 Commercial treatment systems based on chemical disinfection

Several self-contained waste-treatment systems, based on chemical disinfection, have been developed specifically for health-care waste and are available commercially; some have been officially approved for use in several countries. One such system is described in Box 8.12 but numerous others are commercially available or under development, using various disinfectants. Some of these self-contained treatment systems use disinfectants such as chlorine dioxide, which are not described in section 8.2.1. Certain systems are fully automatic and equipped with air filtration systems; they are thus easy to operate and

Box 8.9 Characteristics of glutaraldehyde (CHO-(CH₂)₃-CHO) as a chemical disinfectant

Application

Active against both bacteria and parasite eggs. Available in 25–50% aqueous solutions; should be used as 2% aqueous solution with acetate buffer. Contact times: 5 minutes for disinfection of medical equipment; 10 hours to kill spores. For waste, operating parameters should be adjusted on the basis of bacteriological tests.

Physical and chemical properties

Liquid; very reactive; non-flammable. Addition of methanol allows for long-term conservation.

Health hazards

Concentrated solutions are irritant to eyes and skin; occupational safety limit depends on the country (e.g. 0.2ppm or 0.7mg/m³ in France).

Protective measures

Gloves and protective eye glasses should be worn during handling of glutaraldehyde to protect skin and eyes; in case of skin contact the affected area should be rinsed abundantly with water; in case of eye contact, the eyes should be rinsed abundantly with water for at least 15 minutes, followed by medical examination.

Corrosiveness

Aqueous solutions of glutaraldehyde are corrosive to most metals; usually stored in stainless steel containers, steel containers lined with phenolic resins, or reinforced polyethylene containers, in well ventilated, leakage-proof rooms.

Comments

Glutaraldehyde is suitable for use as a chemical disinfectant only in situations in which a high level of chemical safety can be maintained. Glutaraldehyde waste should never be discharged in sewers; it may be neutralized through careful addition of ammonia or sodium bisulfite; it may also be incinerated after mixing with a flammable solvent.

have a lesser impact on the environment. They can usually be adapted to a range of capacities. Most of these commercial systems shred the waste, and some combine a thermal process; they may be based on wet or dry chemical disinfection. They are not usually adequate for cytotoxic or chemical waste, but some may treat pathological waste. Waste volume is reduced by about 80%.

8.3 Wet and dry thermal treatment

8.3.1 Wet thermal treatment

Wet thermal—or steam—disinfection is based on exposure of shredded infectious waste to high-temperature, high-pressure steam, and is similar to the autoclave sterilization process. It inactivates most types of microorganisms if temperature and contact time are sufficient; for sporulated bacteria, a minimum temperature of 121 °C is needed. About

Box 8.10 Characteristics of sodium hypochlorite (NaOCl) as a chemical disinfectant

Application

Active against most bacteria, viruses, and spores; not effective for disinfection of liquids with high organic content such as blood or stools; widely used for treatment of wastewater. For waste, operating parameters should be adjusted on the basis of bacteriological tests.

Physical and chemical properties

Available as aqueous solution with 2–12% of active chlorine; at ambient temperature slowly decomposes into sodium chlorate, sodium chloride, and oxygen; solutions of low concentration are more stable; solutions should be protected from light which accelerates decomposition; reacts with acids to produce hazardous chlorine gas.

Health hazards

Irritant to skin, eyes, and respiratory tract; toxic.

Protective measures

Gloves and protective eye glasses should be worn during handling of sodium hypochlorite to protect skin and eyes; in case of eye contact, the eyes should be rinsed abundantly with water.

Corrosiveness

Aqueous solutions are corrosive to metals; usually stored in plastic containers in well ventilated, dark, and leakage-proof rooms; should be stored separately from acids.

Comments

Sodium hypochlorite may be widely used because of relatively mild health hazards. Unused solutions should be reduced with sodium bisulfite or sodium thiosulfate and neutralized with acids before discharge into sewers. Large quantities of concentrated solutions should be treated as hazardous chemical waste.

99.99% inactivation of microorganisms may be expected, compared with the 99.9999% achievable with autoclave sterilization.

The wet thermal process requires that waste be shredded before treatment; for sharps, milling or crushing is recommended to increase disinfection efficiency. The process is inappropriate for the treatment of anatomical waste and animal carcasses, and will not efficiently treat chemical or pharmaceutical wastes.

The disadvantages of the wet thermal process are the following:

- the shredder is liable to mechanical failure and breakdown;
- the efficiency of disinfection is very sensitive to the operational conditions.

However, the relatively low investment and operating costs and the low environmental impact are distinct advantages of the wet thermal

Box 8.11 Characteristics of chlorine dioxide (ClO₂) as a chemical disinfectant

Application

Active against most bacteria, viruses, and spores; widely used, for instance in drinking-water preparation, sanitation, and wastewater treatment.

Physical and chemical properties

Reddish-yellow gas at ambient temperature; explosion limit: >10% in air; will react with water or steam to produce corrosive fumes of hydrochloric acid.

Health hazards

Irritant to skin, eyes, and respiratory tract; toxic. NIOSH IDLH: 5 ppm.

Protective measures

In case of eye contact, eyes should be rinsed abundantly with water; contaminated areas of the body should be washed with soap and water.

Corrosiveness

Containers of chlorine dioxide should be stored in well ventilated and leakage-proof rooms.

process, which should be considered when incineration is not practicable. Once disinfected, waste can join the municipal waste collection and disposal mechanism.

Operation and technology

The reacting tank for the wet thermal process may be a horizontal steel cylinder, connected to a steam generator, both of which can withstand a pressure of 6 bar (600 kPa) and a temperature of 160 °C. The system also includes a vacuum pump and an electricity supply. Pressure and temperature are controlled and monitored during the process, and operation of the system may be automated. Wet thermal processes are usually batch systems, but may also be continuous.

At the start of the operation, the waste is shredded and the sharps crushed or milled before being introduced into the tank. Vacuum conditions are established in the tank; this increases the partial pressure of the steam and hence the effectiveness of contact between steam and waste. Superheated steam is then introduced to the tank. A minimal temperature of 121 °C and a pressure usually of 2–5 bar (200–500 kPa) should be maintained during the total contact time of 1–4 hours. Since disinfection efficiency depends upon the extent of contact between the steam and the surface of the waste, the tank should not be overloaded. Optimal operational conditions can be achieved when the waste is finely shredded and does not fill more than half the tank. At the end of the contact time, the reacting tank is cooled down and then emptied and cleaned.

The theoretical contact times needed to achieve disinfection—20 minutes above 121 °C and 2 bar (200 kPa) and 5 minutes above 134 °C and 3.1 bar (310 kPa)—are less than those needed in practice. This is because more

Box 8.12 Self-contained chemical disinfection treatment system^a

After peroxide pretreatment, the waste undergoes shredding and alkaline oxidation by calcium oxide (burnt lime) followed by encapsulation in a siliceous mass. The treated waste is rendered suitable for disposal in landfills without the need for special consideration. The appearance of the processed waste, which is reduced by about 80% in volume, is shown in the photograph.

The process is environmentally friendly and easy to operate.



Infectious waste residues from chemical disinfection by self-contained system

^aPhotograph reproduced with the kind permission of Matrix Technology PTY Ltd, Cairns, Australia.

time may be needed for steam to penetrate certain waste components such as microbiological cultures or hypodermic needles.

The effectiveness of a wet thermal disinfection technique should be routinely checked using the *Bacillus subtilis* or *Bacillus stearothermophilus* tests as outlined in Box 8.13.

The equipment should be operated and maintained by adequately trained technicians; maintenance is required largely for the shredder.

Investment and operating costs

Equipment from many different suppliers is currently available in Europe, North America, and the Pacific region. Investment costs range from US\$ 50 000 to US\$ 200 000 for the full equipment, with tank capacities between 20 litres and 8 m³ and operating temperatures between 120 °C and 160 °C. As an illustration, the cost of wet thermal equipment

Box 8.13 Description of *Bacillus subtilis* and *Bacillus stearothermophilus* tests

- Dried test spores are placed in a thermally resistant and steam-permeable container near the centre of the waste load and the apparatus is operated under normal conditions.
- At the end of the cycle, the test organisms are removed from the load; within 24 hours, test discs or strips should be aseptically inoculated in 5.0ml soybean–casein digest broth medium and incubated for at least 48 hours, at 30°C for *Bacillus subtilis* and at 55°C for *Bacillus stearothermophilus*.
- The media should then be examined for turbidity as a sign of bacterial growth; any growth should be subcultured onto appropriate media to identify the organism either as the test microorganism or as an environmental contaminant.

Fig. 8.7 Off-site wet thermal (or “steam autoclave”) treatment facility

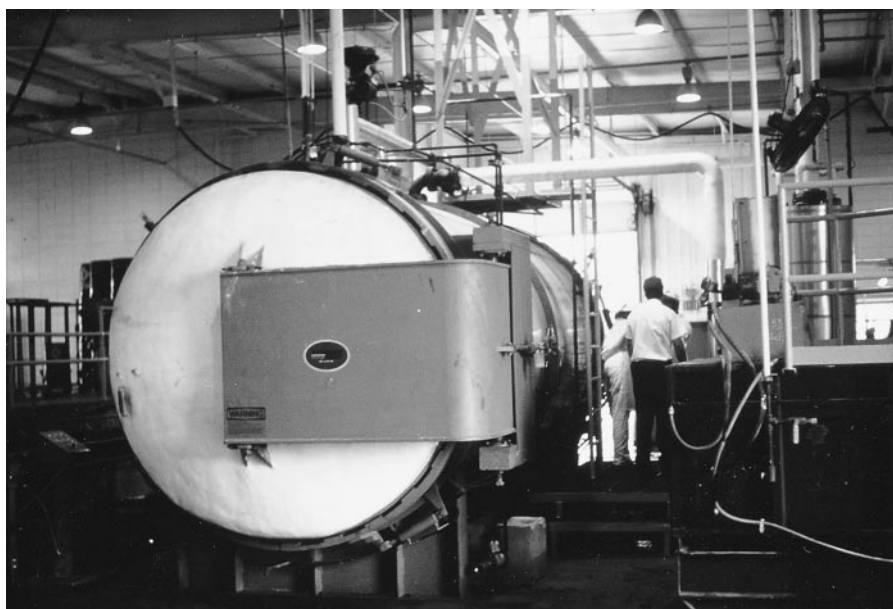

with the capacity to treat 50 tonnes of waste per year is about US\$ 100 000 on the European market; operating costs are about US\$ 400 per tonne of waste (less in developing countries).

Large-scale equipment for off-site treatment

Large-scale wet thermal (or “steam autoclave”) disinfection equipment with reacting tanks of capacities up to 8m³ or more may be used for regional health-care waste treatment facilities. Their technical characteristics are similar to those of small systems, but some operate without shredders. Some systems may also treat anatomical waste (which becomes unrecognizable). An increasing number of health-care waste treat-

ment facilities around the world are using the wet thermal process (see Fig. 8.7).

Recommendations for minimal programmes

Because of the need for regular maintenance of the shredder in most systems, and the requirement to establish vacuum conditions in the exposure tank, which is a delicate operation requiring qualified technicians, the wet thermal process is not particularly recommended for minimal programmes. It should only be considered by hospitals with the necessary technical and financial resources, and in places where single-chamber incineration or bunker burning of waste is not acceptable, for example because of the air pollution problems that may result.

Autoclaving

Autoclaving is an efficient wet thermal disinfection process. Typically, autoclaves are used in hospitals for the sterilization of reusable medical equipment. They allow for the treatment of only limited quantities of waste and are therefore commonly used only for highly infectious waste, such as microbial cultures or sharps. It is recommended that all general hospitals, even those with limited resources, be equipped with autoclaves.

The advantages and disadvantages of autoclaving wastes are the same as for other wet thermal processes discussed in this section. The physical requirements for effective steam autoclave treatment are normally different from those required for sterilizing medical supplies. Minimum contact times and temperatures will depend on several factors such as the moisture content of the waste and ease of penetration of the steam. Research has shown that effective inactivation of all vegetative microorganisms and most bacterial spores in a small amount of waste (about 5–8 kg) requires a 60-minute cycle at 121 °C (minimum) and 1 bar (100 kPa); this allows for full steam penetration of the waste material.

Figure 8.8 shows an on-site steam autoclave for health-care waste treatment

Fig. 8.8 On-site steam autoclave



Fig. 8.9 Schematic plan of a self-contained screw-feed unit^a

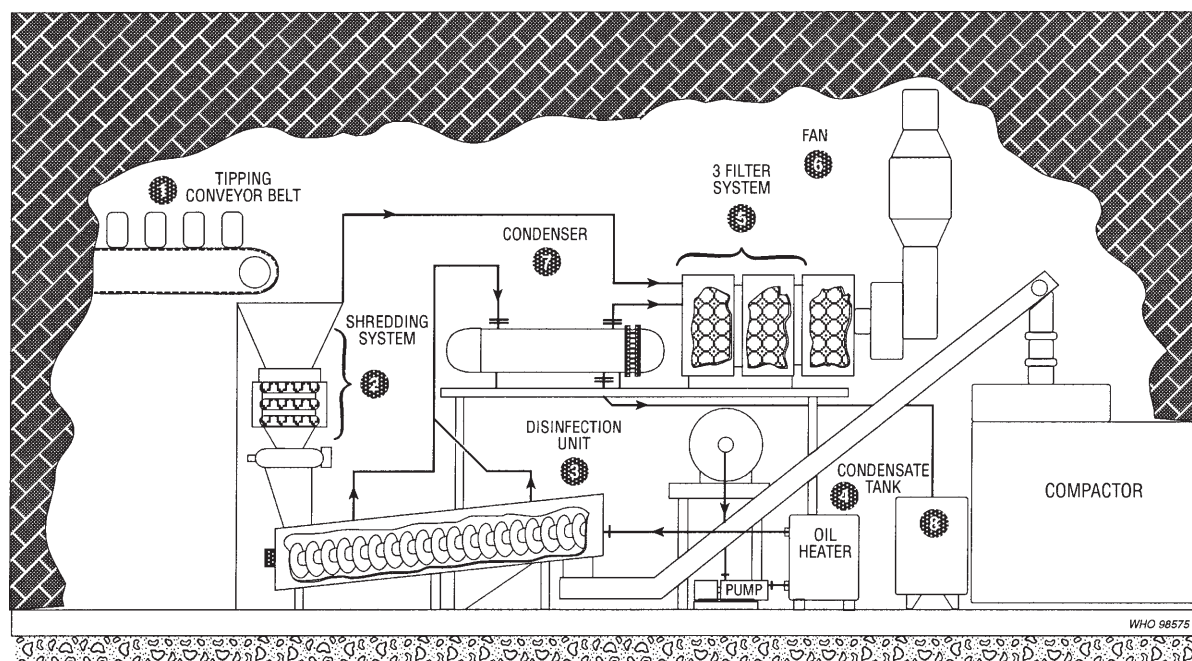

^aReproduced with the kind permission of ScotSafe Ltd, Glasgow, Scotland.

8.3.2 Screw-feed technology

Screw-feed technology is the basis of a non-burn, dry thermal disinfection process in which waste is shredded and heated in a rotating auger. Continuously operated units, also called continuous feed augers, are commercially available and already in use in several hospitals. The principal steps of the process are the following:

- The waste is shredded to particles about 25 mm in diameter.
- The waste enters the auger, which is heated to a temperature of 110–140 °C by oil circulating through its central shaft.
- The waste rotates through the auger for about 20 minutes, after which the residues are compacted.

The waste is reduced by 80% in volume and by 20–35% in weight. This process is suitable for treating infectious waste and sharps, but it should not be used to process pathological, cytotoxic, or radioactive waste. Exhaust air should be filtered, and condensed water generated during the process should be treated before discharge.

A typical self-contained screw-feed unit is shown schematically in Fig. 8.9.

8.4 Microwave irradiation

Most microorganisms are destroyed by the action of microwaves of a frequency of about 2450 MHz and a wavelength of 12.24 cm. The water contained within the wastes is rapidly heated by the microwaves and the infectious components are destroyed by heat conduction.

Fig. 8.10 Microwave treatment unit for health-care waste



In a microwave treatment unit, a loading device transfers the wastes into a shredder, where it is reduced to small pieces. The waste is then humidified, transferred to the irradiation chamber, which is equipped with a series of microwave generators, and irradiated for about 20 minutes. A typical self-contained microwave system is shown in Fig. 8.10. After irradiation, the waste is compacted inside a container and enters the municipal waste stream.

The efficiency of microwave disinfection should be checked routinely through bacteriological and virological tests. In the USA, a routine bacteriological test using *Bacillus subtilis* is recommended to demonstrate a 99.99% reduction of viable spores. The testing procedure is similar to that described for wet thermal disinfection (see Box 8.13).

The microwave process is widely used in several countries and is becoming increasingly popular. However, relatively high costs coupled with potential operation and maintenance problems mean that it is not yet recommended for use in developing countries. Similar processes using other wavelengths or electron beams are also being developed.

Microwave irradiation equipment with a capacity of 250 kg/hour (3000 tonnes/year), including loading device, shredder, steam humidification tank, irradiation chamber, and microwave generators, plus a waste compactor, may cost about US\$ 0.5 million. More compact systems have recently been developed to treat health-care waste at the point of production. They are of considerably lower capacity, but are much cheaper.

8.5 Land disposal

8.5.1 Municipal disposal sites

If a municipality or medical authority genuinely lacks the means to treat wastes before disposal, the use of a landfill has to be regarded as an

Fig. 8.11 Routes of exposure to hazards caused by open dumping^a

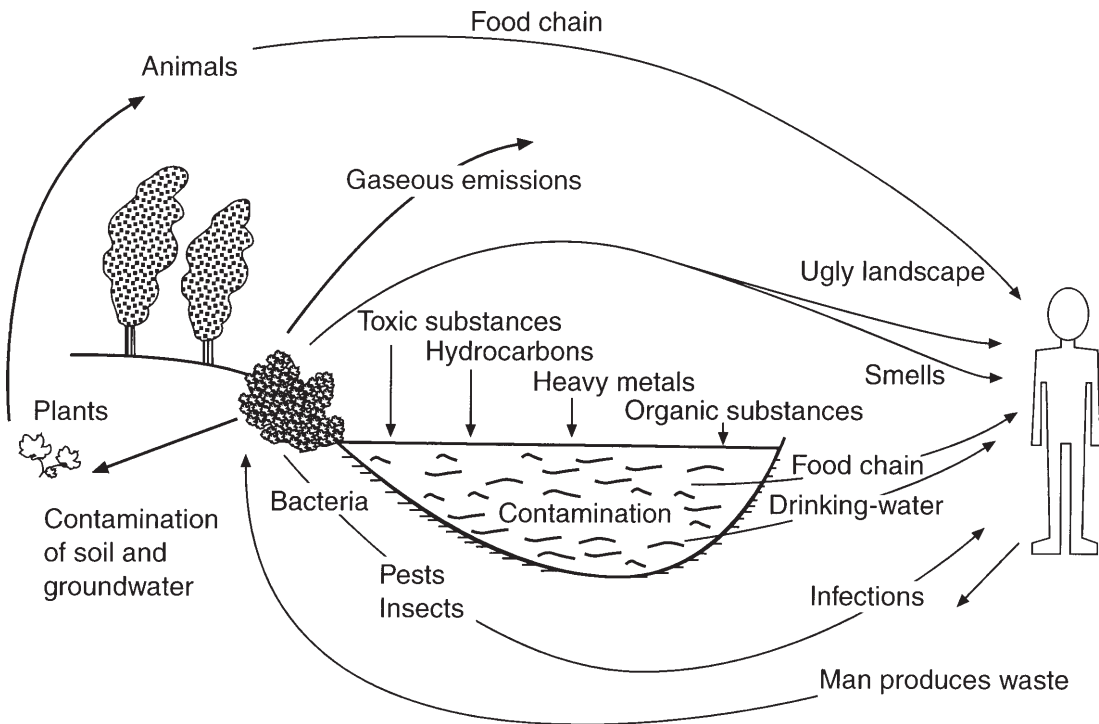

^aSource: Oeltzschner (1996); reproduced with the kind permission of Deutsche Gesellschaft für Technische Zusammenarbeit GmbH.

WHO/98/370

acceptable disposal route. Allowing health-care waste to accumulate at hospitals or elsewhere constitutes a far higher risk of the transmission of infection than careful disposal in a municipal landfill, even if the site is not designed to the standard used in higher-income countries. The primary objections to landfill disposal of hazardous health-care waste, especially untreated waste, may be cultural or religious or based on a perceived risk of the release of pathogens to air and water or on the risk of access by scavengers.

There are two distinct types of waste disposal to land—*open dumps* and *sanitary landfills*.

- *Open dumps* are characterized by the uncontrolled and scattered deposit of wastes at a site; this leads to acute pollution problems, fires, higher risks of disease transmission, and open access to scavengers and animals. **Health-care waste should not be deposited on or around open dumps.** The risk of either people or animals coming into contact with infectious pathogens is obvious, with the further risk of subsequent disease transmission, either directly through wounds, inhalation, or ingestion, or indirectly through the food chain or a pathogenic host species (see Fig. 8.11).
- *Sanitary landfills* are designed to have at least four advantages over open dumps: geological isolation of wastes from the environment, appropriate engineering preparations before the site is ready to accept wastes, staff present on site to control operations, and organized deposit and daily coverage of waste. Some of the rules applicable to

Box 8.14 Some essential elements for design and operation of sanitary landfills

- Access to site and working areas possible for waste delivery and site vehicles.
- Presence of site personnel capable of effective control of daily operations.
- Division of the site into manageable phases, appropriately prepared, before landfill starts.
- Adequate sealing of the base and sides of the site to minimize the movement of wastewater (leachate) off the site.
- Adequate mechanisms for leachate collection, and treatment systems if necessary.
- Organized deposit of wastes in a small area, allowing them to be spread, compacted, and covered daily.
- Surface water collection trenches around site boundaries.
- Construction of a final cover to minimize rainwater infiltration when each phase of the landfill is completed.

sanitary landfills are listed in Box 8.14. Disposing of certain types of health-care waste (infectious waste and small quantities of pharmaceutical waste) in sanitary landfills is acceptable; sanitary landfill prevents contamination of soil and of surface water and groundwater, and limits air pollution, smells, and direct contact with the public.

Upgrading from open dumping directly to sophisticated sanitary landfills may be technically and financially difficult for many municipalities. It has often been found impossible to sustain such efforts from the available local resources. However, this is no reason for municipal authorities to abandon the move towards safer land disposal techniques, perhaps by a gradual approach, such as that outlined in Box 8.15.

In the absence of sanitary landfills, any site from a controlled dump upwards could accept health-care waste and avoid any measurable increase in infection risk. The minimal requirements would be the following:

- an established system for rational and organized deposit of wastes which could be used to dispose of health-care wastes;
- some engineering work already completed to prepare the site to retain its wastes more effectively;
- rapid burial of the health-care waste, so that as much human or animal contact as possible is avoided.

It is further recommended that health-care waste be deposited in one of the two following ways:

Box 8.15 Proposed pathway for gradual upgrading of landfills¹

1. **From open dumping to “controlled dumping”.** This involves reduction of the working area of the site to a more manageable size (2ha for a medium-size town), covering unneeded areas of the site with soil, extinguishing fires, and agreeing rules of on-site working with scavengers if they cannot be excluded completely.
2. **From controlled dumping to “engineered landfill”.** This involves the gradual adoption of engineering techniques to prevent surface water from entering the waste, extract and spread soils to cover wastes, gather wastewater (leachate) into lagoons, spread and compact waste into thinner layers, prepare new parts of the landfill with excavation equipment, and isolate the waste from the surrounding geology (e.g. with plastic sheeting under the waste).
3. **From engineered landfill to “sanitary landfill”.** This involves the continuing refinement, with increasing design and construction complexity, of the engineering techniques begun for engineered landfill. In addition, there should be landfill gas control measures, environmental monitoring points and bore holes (for monitoring air and groundwater quality), a highly organized and well trained work force, detailed record-keeping by the site office, and, in some circumstances, on-site treatment of leachate.

¹ Adapted from Rushbrook & Pugh (1997).

- In a shallow hollow excavated in mature municipal waste in the layer below the base of the working face, and immediately covered by a 2-metre layer of fresh municipal waste. Scavenging in this part of the site must be prevented. The same method is often used for hazardous solid industrial wastes; it is specifically intended to prevent animals and scavengers from re-excavating the deposited health-care waste.
- In a deeper (1–2m) pit excavated in mature municipal waste (i.e. waste covered at least 3 months previously). The pit is then backfilled with the mature municipal waste that was removed. Scavenging in this part of the site must be prevented.

Alternatively, a special *small burial pit* could be prepared to receive health-care waste only. The pit should be 2m deep and filled to a depth of 1–1.5 m. After each waste load, the waste should be covered with a soil layer 10–15cm deep. If coverage with soil is not possible, lime may be deposited over the waste. In case of outbreak of an especially virulent infection (such as Ebola virus), both lime and soil cover may be added. Access to this dedicated disposal area should be restricted, and the use of a pit would make supervision by landfill staff easier and thus prevent scavenging. A typical example of pit design for health-care waste is shown in Fig. 8.12.

Before health-care wastes are sent for disposal, it is prudent to inspect landfill sites to ensure that there is sensible control of waste deposition.

Fig. 8.12 Example of a small burial pit for health-care waste

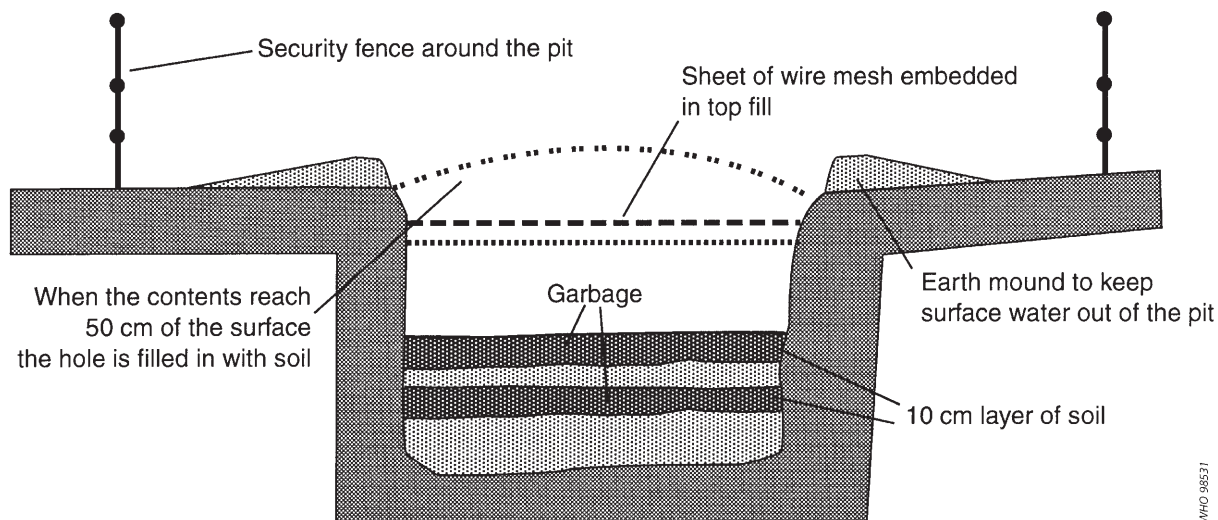

8.5.2 Encapsulation

Disposal of health-care waste in municipal landfills is less advisable if it is untreated than if it is pretreated. One option for pretreatment is encapsulation, which involves filling containers with waste, adding an immobilizing material, and sealing the containers. The process uses either cubic boxes made of high-density polyethylene or metallic drums, which are three-quarters filled with sharps and chemical or pharmaceutical residues. The containers or boxes are then filled up with a medium such as plastic foam, bituminous sand, cement mortar, or clay material. After the medium has dried, the containers are sealed and disposed of in landfill sites.

This process is relatively cheap, safe, and particularly appropriate for establishments that practise **minimal programmes** for the disposal of sharps and chemical or pharmaceutical residues. Encapsulation alone is not recommended for non-sharp infectious waste, but may be used in combination with burning of such waste. The main advantage of the process is that it is very effective in reducing the risk of scavengers gaining access to the hazardous health-care waste.

8.5.3 Safe burial on hospital premises

In health-care establishments that use minimal programmes for health-care waste management, particularly in remote locations, in temporary refugee encampments, or in areas experiencing exceptional hardship, the safe burial of waste on hospital premises may be the only viable option available at the time. However, certain basic rules should still be established by the hospital management:

- Access to the disposal site should be restricted to authorized personnel only.
- The burial site should be lined with a material of low permeability, such as clay, if available, to prevent pollution of any shallow groundwater that may subsequently reach nearby wells.

- Only hazardous health-care waste should be buried. If general hospital waste were also buried on the premises, available space would be quickly filled up.
- Large quantities (>1 kg) of chemical wastes should not be buried at one time. Burying smaller quantities avoids serious problems of environmental pollution.
- The burial site should be managed as a landfill, with each layer of waste being covered with a layer of earth to prevent odours, as well as to prevent rodents and insects proliferating.

The safety of waste burial depends critically on rational operational practices. The design and use of the burial pit are described in the previous section and illustrated in Fig. 8.12. The bottom of the pit should be at least 1.5 metres higher than the groundwater level.

Table 8.4 Summary of main advantages and disadvantages of treatment and disposal options

Treatment/ disposal method	Advantages	Disadvantages
Rotary kiln	Adequate for all infectious waste, most chemical waste, and pharmaceutical waste.	High investment and operating costs.
Pyrolytic incineration	Very high disinfection efficiency. Adequate for all infectious waste and most pharmaceutical and chemical waste.	Incomplete destruction of cytotoxics. Relatively high investment and operating costs.
Single-chamber incineration	Good disinfection efficiency. Drastic reduction of weight and volume of waste. The residues may be disposed of in landfills. No need for highly trained operators. Relatively low investment and operating costs.	Significant emissions of atmospheric pollutants. Need for periodic removal of slag and soot. Inefficiency in destroying thermally resistant chemicals and drugs such as cytotoxics.
Drum or brick incinerator	Drastic reduction of weight and volume of the waste. Very low investment and operating costs.	Destroys only 99% of microorganisms. No destruction of many chemicals and pharmaceuticals. Massive emission of black smoke, fly ash, toxic flue gas, and odours.
Chemical disinfection ^a	Highly efficient disinfection under good operating conditions. Some chemical disinfectants are relatively inexpensive. Drastic reduction in waste volume.	Requires highly qualified technicians for operation of the process. Uses hazardous substances that require comprehensive safety measures. Inadequate for pharmaceutical, chemical, and some types of infectious waste.
Wet thermal treatment ^a	Environmentally sound. Drastic reduction in waste volume. Relatively low investment and operating costs.	Shredders are subject to frequent breakdowns and poor functioning. Operation requires qualified technicians. Inadequate for anatomical, pharmaceutical, and chemical waste and waste that is not readily steam-permeable.
Microwave irradiation	Good disinfection efficiency under appropriate operating conditions. Drastic reduction in waste volume. Environmentally sound.	Relatively high investment and operating costs. Potential operation and maintenance problems.
Encapsulation	Simple, low-cost, and safe. May also be applied to pharmaceuticals.	Not recommended for non-sharp infectious waste.
Safe burying	Low costs. Relatively safe if access to site is restricted and where natural infiltration is limited.	Safe only if access to site is limited and certain precautions are taken.
Inertization	Relatively inexpensive.	Not applicable to infectious waste.

^aMay not apply to more sophisticated, self-contained, commercial methods.

It should be borne in mind that safe on-site burial is practicable only for relatively limited periods, say 1–2 years, and for relatively small quantities of waste, say up to 5 or 10 tonnes in total. Where these conditions are exceeded, a longer-term solution, probably involving disposal at a municipal solid waste landfill, will need to be found.

8.5.4 Land disposal of residues

After disinfection or incineration, infectious health-care waste becomes non-risk waste and may be finally disposed of in landfill sites. However, certain types of health-care waste, such as anatomical waste, will still have an offensive visual impact after disinfection, and this is culturally unacceptable in many countries. Such wastes should therefore be made unrecognizable before disposal, for example by incineration. If this is not possible, these wastes should be placed in containers before disposal.

8.6 Inertization

The process of “inertization” involves mixing waste with cement and other substances before disposal in order to minimize the risk of toxic substances contained in the waste migrating into surface water or groundwater. It is especially suitable, for pharmaceuticals and for incineration ashes with a high metal content (in this case the process is also called “stabilization”).

For the inertization of pharmaceutical waste, the packaging should be removed, the pharmaceuticals ground, and a mixture of water, lime, and cement added. A homogeneous mass is formed and cubes (e.g. of 1 m³) or pellets are produced on site and then can be transported to a suitable storage site. Alternatively, the homogeneous mixture can be transported in liquid state to a landfill and poured into municipal waste.

The following are typical proportions for the mixture:

- 65% pharmaceutical waste
- 15% lime
- 15% cement
- 5% water

The process is reasonably inexpensive and can be performed using relatively unsophisticated equipment. Other than personnel, the main requirements are a grinder or road roller to crush the pharmaceuticals, a concrete mixer, and supplies of cement, lime, and water.

The main advantages and disadvantages of the various treatment and disposal options addressed in this handbook are outlined in Table 8.4.

References and suggested further reading

- Andrychowski J (1988). *Les déchets hospitaliers et leur incinération, principes de combustion, évolution technologique des fours. [Hospital waste: incineration, principles of combustion, technological development in incinerators.]* Paris, Centre de formation et de documentation sur l'environnement industriel.
- Bonnard & Gardel (1990). *Plan sectoriel des déchets d'hôpitaux, Canton de Fribourg. [Canton of Fribourg: sectoral hospital waste scheme.]* Geneva, Bonnard & Gardel Ingénieurs-Conseils SA.

- Bartone C (1998). Municipal solid waste management. In: *Brazil: managing pollution problems—the brown environmental agenda*. Washington, DC, World Bank (Report No. 16635).
- Brunner CPE (1989). *Handbook of hazardous waste incineration*. Blue Ridge Summit, PA, TAB Books.
- Canadian Council of Ministers of the Environment (1992). *Guidelines for the management of biomedical waste in Canada*. Winnipeg (CCME/EPC-WM-42E).
- Christen J (1996). *Dar es Salaam Urban Health Project. Health care waste management in district facilities: situational analysis and system development*. St. Gallen, Switzerland, Swiss Centre for Development Cooperation in Technology and Management (SKAT).
- Constructions navales et industrielles de la Méditerranée (1992). *Four de pyrolyse par torche à plasma pour destruction de déchets. [Pyrolytic destruction of waste by plasma torch.]* Nantes.
- Cross F, Hesketh H, Rykowski K (1990). *Infectious waste management*. Lancaster, PA, Technomic Publishing.
- Danish Waste Management Association/Association of Danish Hospital Administrators (DAKFA/FSAD) (1991). *Waste. European conference on hospital waste management*. Copenhagen.
- Dunsmore DJ (1986). *Safety measures for use in outbreaks of communicable disease*. Geneva, World Health Organization.
- Liberti A et al. (1994). Optimization of infectious hospital waste management in Italy. Part 1: Waste production and characterization study. *Waste management and research*, 12:373–385.
- Ministère de la Santé (1990). *Guide sur l'élimination des déchets hospitaliers. [Guide to hospital waste disposal.]* Paris.
- Ministère de la Santé (1991). *Élimination des déchets produits par les professionnels de santé en exercice libéral, enquête sur les conditions actuelles d'élimination. [Disposal of waste produced by health professionals in the course of their duties and survey of current waste disposal conditions.]* Paris.
- Ministère de la Santé (1991). *Enquête nationale sur les conditions actuelles d'élimination des déchets solides hospitaliers. [National survey on current hospital waste disposal conditions.]* Paris.
- Oeltzschner H, Mutz D (1996). *Guidelines for an appropriate management of domestic sanitary landfills*. Eschborn, Gesellschaft für Technische Zusammenarbeit.
- Office fédéral suisse de la santé publique/Bonnard & Gardel Ingénieurs-Conseils SA (1994). *Analyse des méthodes d'élimination des déchets infectieux hospitaliers. [Analysis of disposal methods for infectious hospital waste.]* Berne.
- Reinhardt PA, Gordon JH (1991). *Infectious and medical waste*. Chelsea, MI, Lewis Publishers.
- Rushbrook PK, Pugh MP (1997). *Decision-maker's guide on the planning, siting, design and operation of sanitary landfills in middle- and lower-income countries*. To be published collaboratively by WHO/SKAT/World Bank, 1997.
- L'élimination des déchets. [Waste disposal.] *Techniques hospitalières*, 1991, 554 (numéro spécial).
- WHO (1985). *Solid waste management selected topics*. Copenhagen, World Health Organization Regional Office for Europe.
- WHO (1996). *Suggested guiding principles and practices for the sound management of hazardous hospital wastes. Regional Consultation on Sound Management of Hospital Waste in Chiang Mai, Thailand, November 1996*. New Delhi, World Health Organization Regional Office for South-East Asia.
- WHO (1996). *Healthy cities—healthy islands. Guides for municipal solid waste management in Pacific Island countries*. Manila, World Health Organization Regional Office for the Western Pacific (Document Series, No. 6).